



RENTAL

NOLEGGIO | VERMIETUNG

inag
I T A L I A

MOVING
SOLUTION

MC 45S



*Elektrica - semplice -
radiocomandata Electric - simple -
radio controlled Elektrisch - einfach -
- Funkgesteuert*



*Massima capacità
Max capacity
Maximale Kapazität*

4.500 Kg



*Dimensioni mm
Dimensions mm
Maße mm*

2775x1200x1648



*48V 600 Ah - 8 ore di autonomia
48V 600 Ah - 8 hours of autonomy
48V 600 Ah - 8 Stunden Autonomie*



*Angolo di inclinazione +60°/-15°
Angle of inclination +60°/-15°
Neigungswinkel +60°/-15°*



*Motore elettrico 9kW- 48 V AC
Classe d'isolamento H
Electric motor 9kW- 48V
AC Insulation class H
9kW- 48 V AC Elektromotor
Isolationsklasse H*



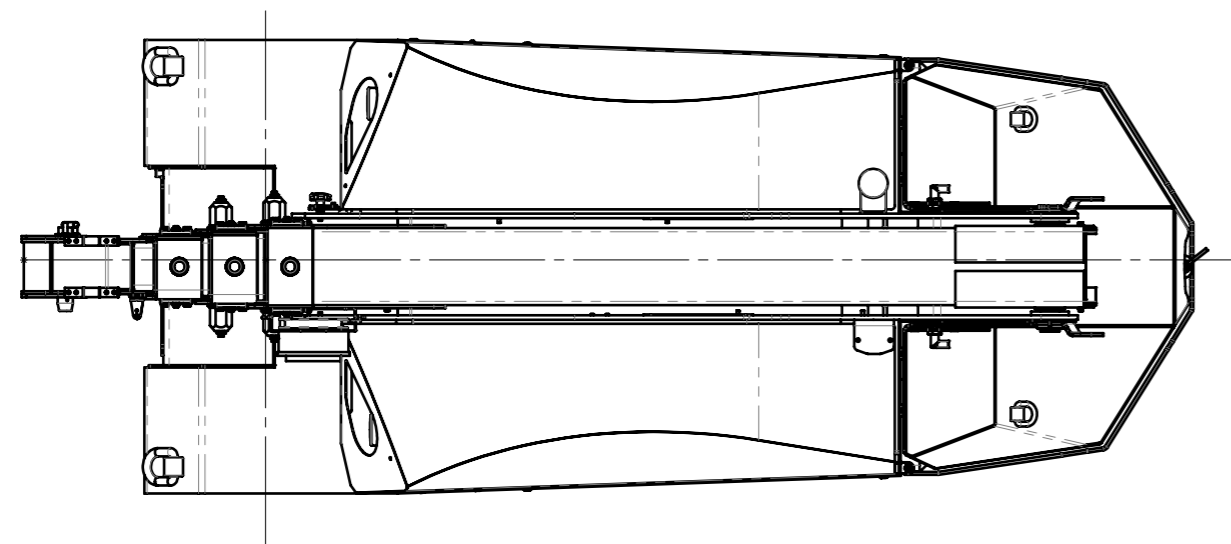
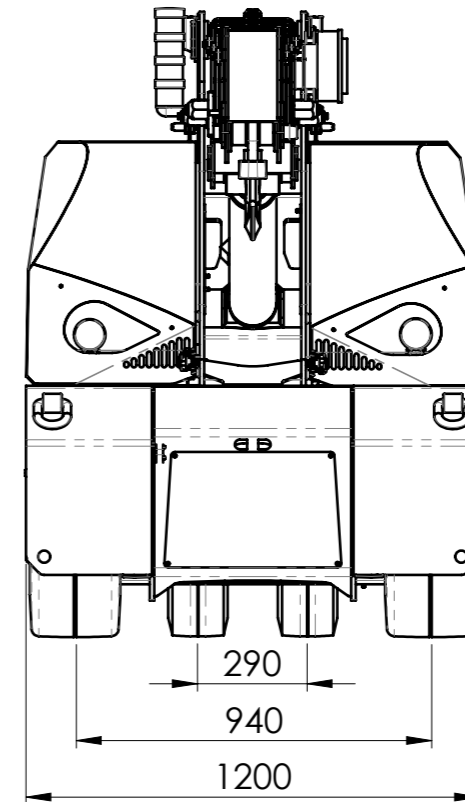
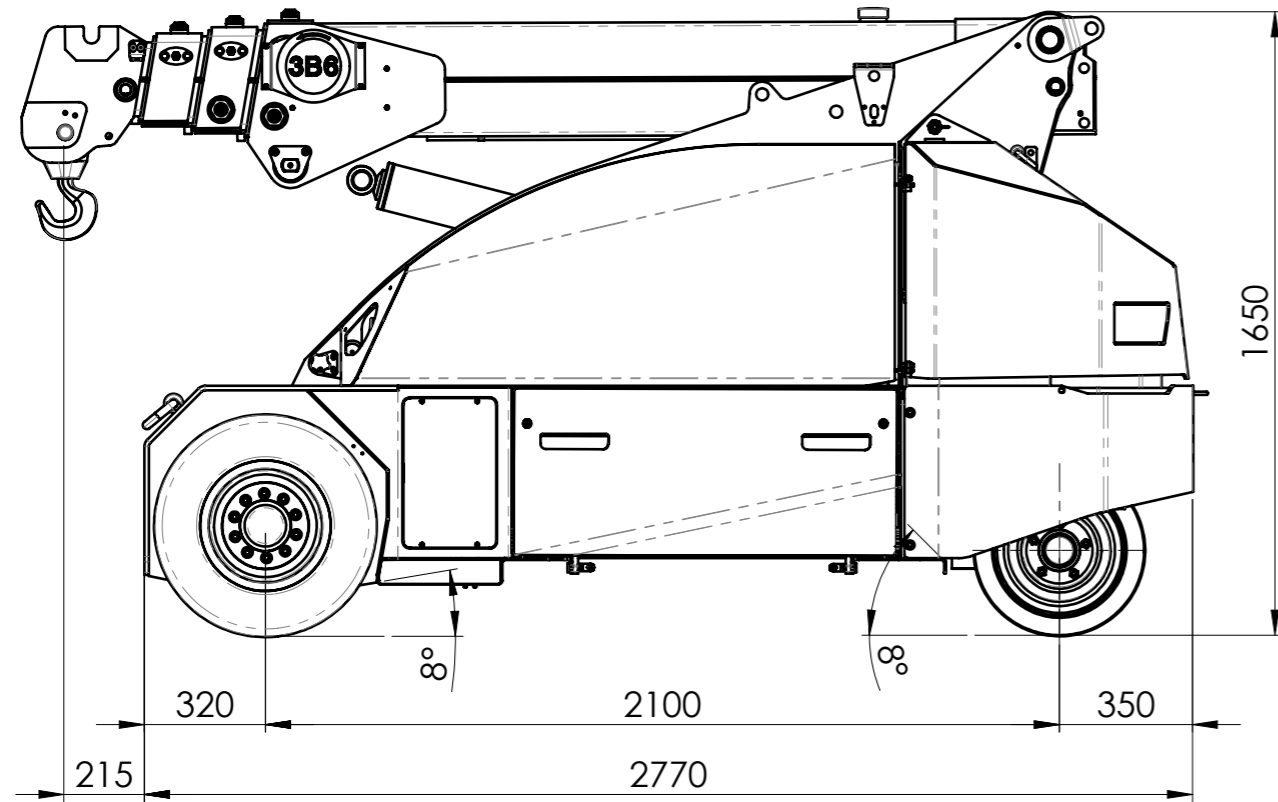

REVISIONE	DESCRIZIONE MODIFICA	APPROVATA DA	APPROVATA DATA
01		Emilio Berti	24/10/2016
00	EMISSIONE	Emilio Berti	06/10/2016

CODICE	000-COM-00380	REVISIONE	FOGLIO	SCALA	MASSA (kg)	MATERIA PRIMA	TRATTAMENTO
		01	1 di 1	1:20	4753.51		

DESCRIZIONE	MC 45S	SALDATURA			DISEGNATO DA	APPROVATO DA
		DOVE NON INDICATO ESEGUIRE LE SALDATURE A FILO CONTINUO MAG SOTTO PROTEZIONE GASSOSA, TIPO SCHUTZGAS FILO TIPO ESC C5-3 DIN 8559. LE SALDATURE NON INDICATE DEVONO ESSERE ESEGUITE COL MINIMO DI SPESSORE PARI AL METALLO BASE.			DATA	24/10/2016
					FIRMA	Emilio Berti

	Tolleranze generali secondo UNI EN 22768-mK	RUGOSITA' Ra in µm	12.5 / (3.2 / 0.8 / 0.4)
--	---	--------------------	--------------------------

DIAGRAMMA DELLE PORTATE (t)
 CAPACITY DIAGRAM (t)
 TRAGLASTDIAGRAMM (t)
 LASTENDIAGRAM (t)
 TABLEAU DES CHARGES (t)
 DIAGRAMA DE LAS CARGAS (t)
 WYKRES OBCIAZEN (t)



DIAGRAMMA DELLE PORTATE (t)
 CAPACITY DIAGRAM (t)
 TRAGLASTDIAGRAMM (t)
 LASTENDIAGRAMM (t)
 TABLEAU DES CHARGES (t)
 DIAGRAMA DE LAS CARGAS (t)

JMG

MILANO - ITALY

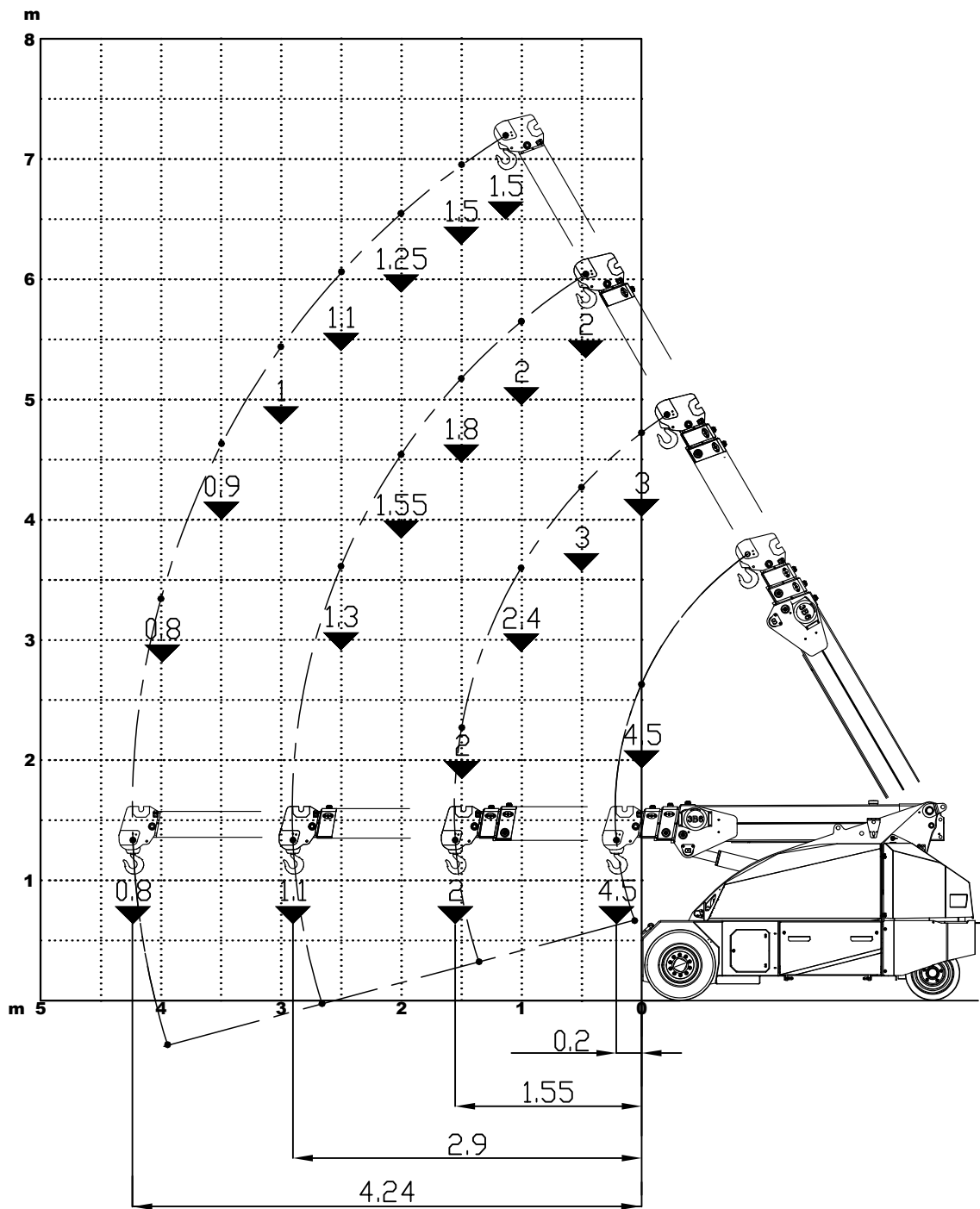
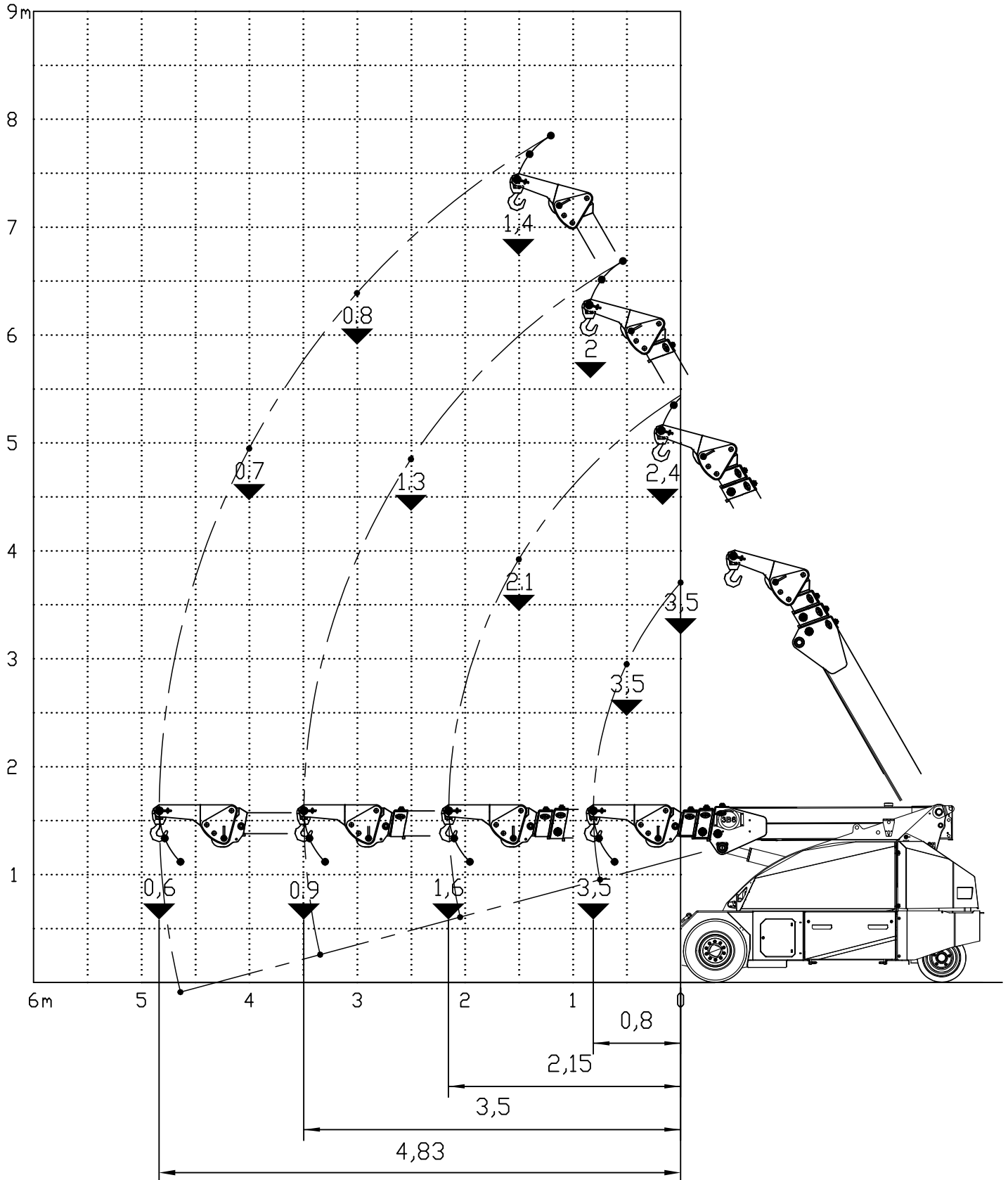

MC45S Z1+Z2

COD. 090-DIA-01218 00 H:1:50

DIAGRAMMA DELLE PORTATE (t)
 CAPACITY DIAGRAM (t)
 TRAGLASTDIAGRAMM (t)
 LASTENDIAGRAMM (t)
 TABLEAU DES CHARGES (t)
 DIAGRAMA DE LAS CARGAS (t)

JMG

MILANO - ITALY

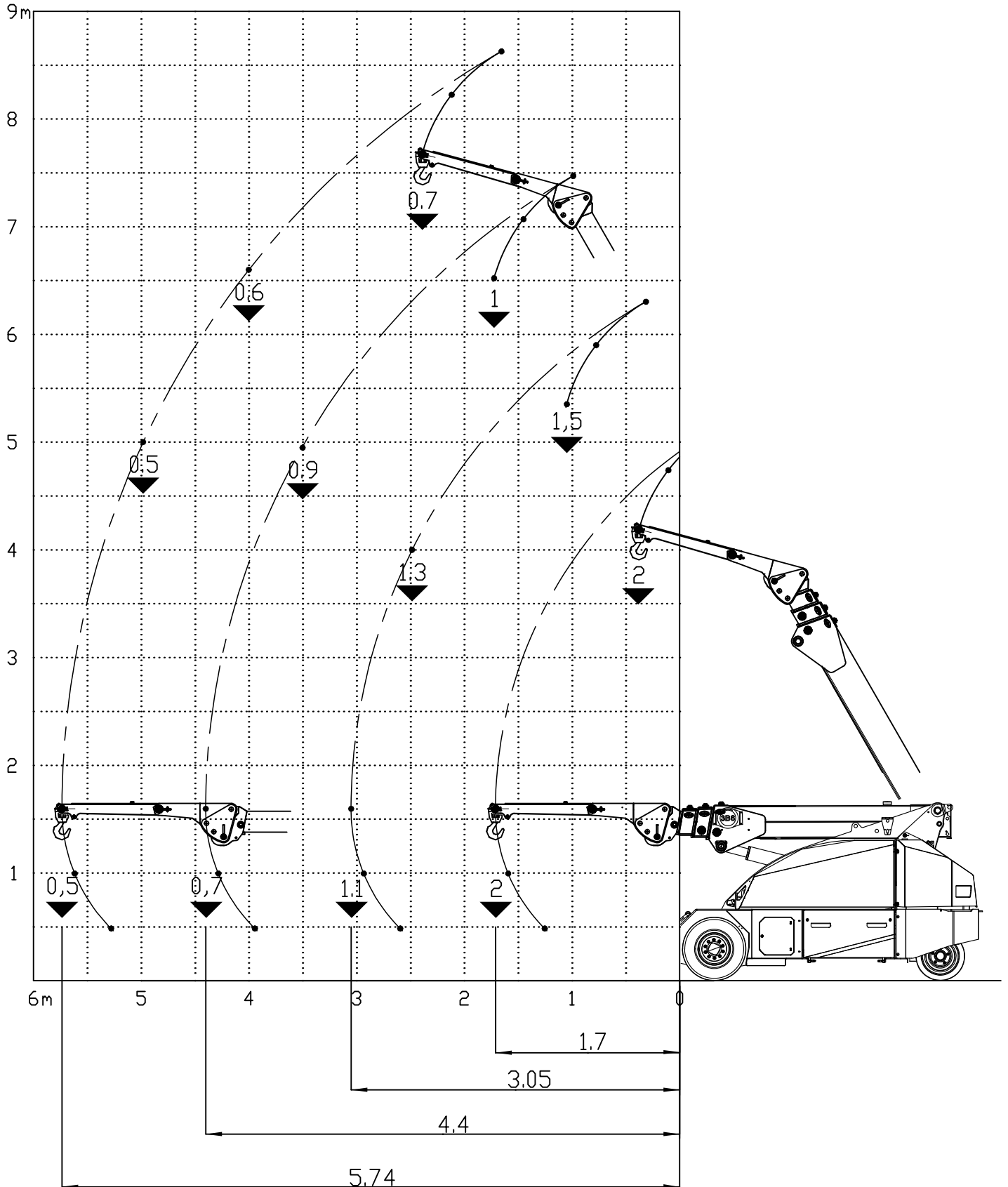

MC45S

Z1+Z2

COD. 090-DIA-01230 00 H:1:50