



MOVING
SOLUTION

RENTAL

NOLEGGIO | VERMIETUNG

MC 32S



Elektrica - radiocomandata
Electric - radio controlled
Elektrisch - Funkgesteuert



Massima capacità
Max capacity
Maximale Kapazität

3.200 Kg



Dimensioni mm
Dimensions mm
Maße mm

2430x980x1696



48V 500 Ah - 8 ore di autonomia
48V 500 Ah - 8 hours of autonomy
48V 500 Ah - 8 Stunden Autonomie



Angolo di inclinazione +65°/-15°
Angle of inclination +60°/-15°
Neigungswinkel +60°/-15°



Motore elettrico 9kW- 48 V AC
Classe d'isolamento H
Electric motor 9kW- 48V AC
Insulation class H
9kW- 48 V AC Elektromotor
Isolationsklasse H



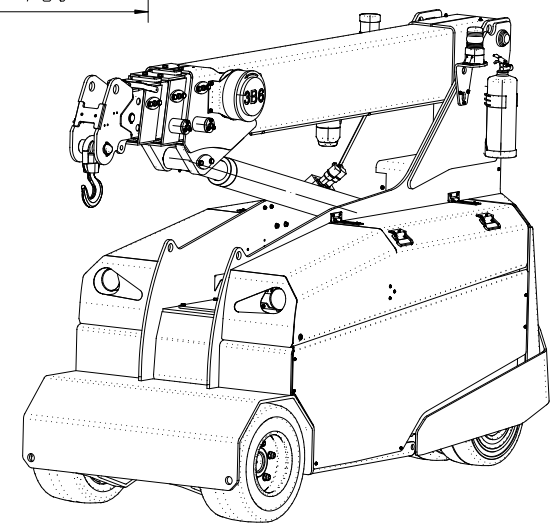
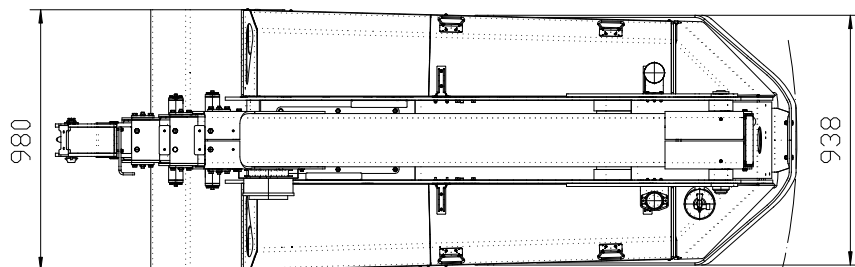
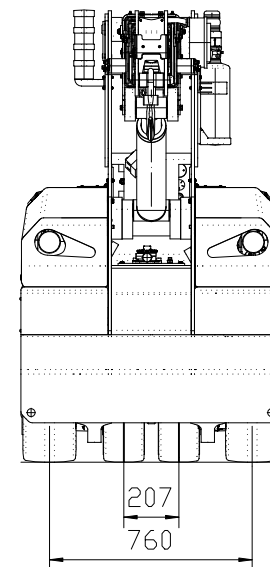
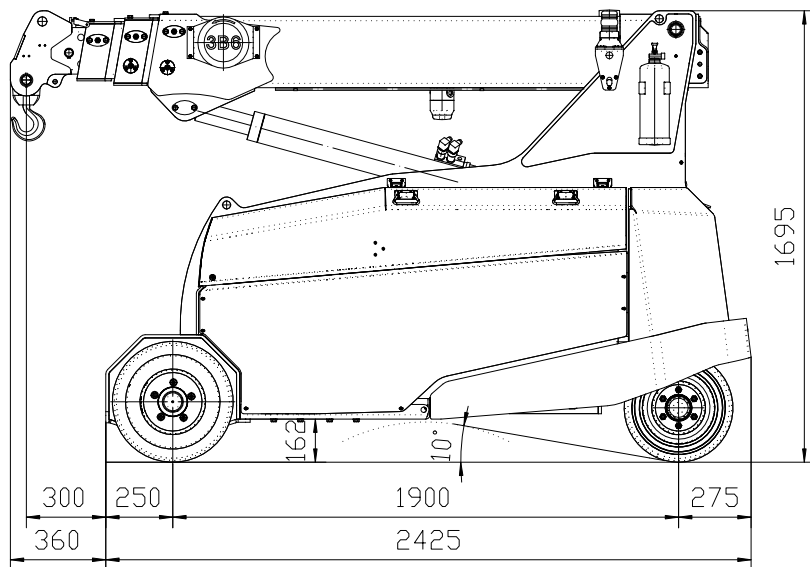

MODIFICHE	INDICE	1	2	3	4	MASSA kg	SOSTITUISCE IL	SCALA 1:1	COMMESSA N°	PEZZI 0	
	DATA						SOSTITUITO DAL				
	FIRMA						DATA				
	DISEGNATO DA	CONTROLLATO DA	APPROVATO DA	QUOTE SENZA TOLLERANZA	RAGGI NON QUOTATI R 0,5	SALDATURA					
	DATA	02/04/2013		Tolleranze secondo ISO 8015	SMUSSI NON QUOTATI 0,5x45°	IN ASSENZA DI ALTRE SPECIFICAZIONI, ESEGUIRE LE SALDATURE SECONDO LA PROCEDURA UNI EN ISO 15607 E UNI EN ISO 15614-1, O ALTRE EQUIPARABILI.					
	FIRMA	E.B.		Tolleranze generali secondo ISO 2768-ck	RUGOSITA' Ra in 3mm	$125/ \sqrt{\text{Ra}}$ (32/08)					
						OGGETTO MC32 - DIMENSIONI D'INGOMBRO					
						CODICE DISEGNO 000-SCH-00213			FOGLIO 1/1	REVIS. 00	

DIAGRAMMA DELLE PORTATE (t)
 CAPACITY DIAGRAM (t)
 TRAGLASTDIAGRAMM (t)
 LASTENDIAGRAM (t)
 TABLEAU DES CHARGES (t)
 DIAGRAMA DE LAS CARGAS (t)
 WYKRES OBCIAZEN (t)
 DIAGRAMMA GRUZOPOD*YEMNOSTI (t)

JMG

MILANO - ITALY

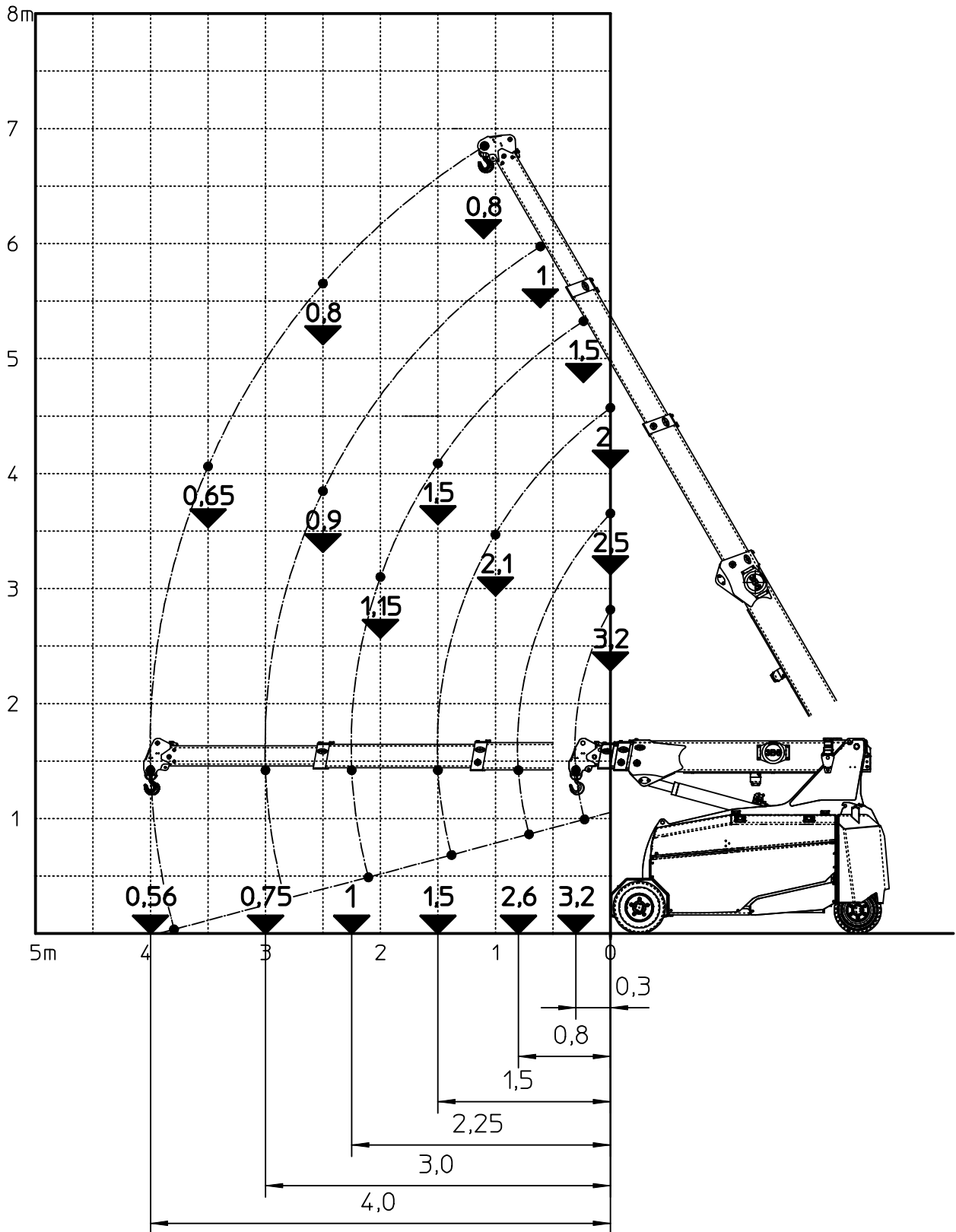

MC32

COD. 090-DIA-0064100 H1:50

DIAGRAMMA DELLE PORTATE (t)
 CAPACITY DIAGRAM (t)
 TRAGLASTDIAGRAMM (t)
 LASTENDIAGRAM (t)
 TABLEAU DES CHARGES (t)
 DIAGRAMA DE LAS CARGAS (t)

JMG

MILANO - ITALY

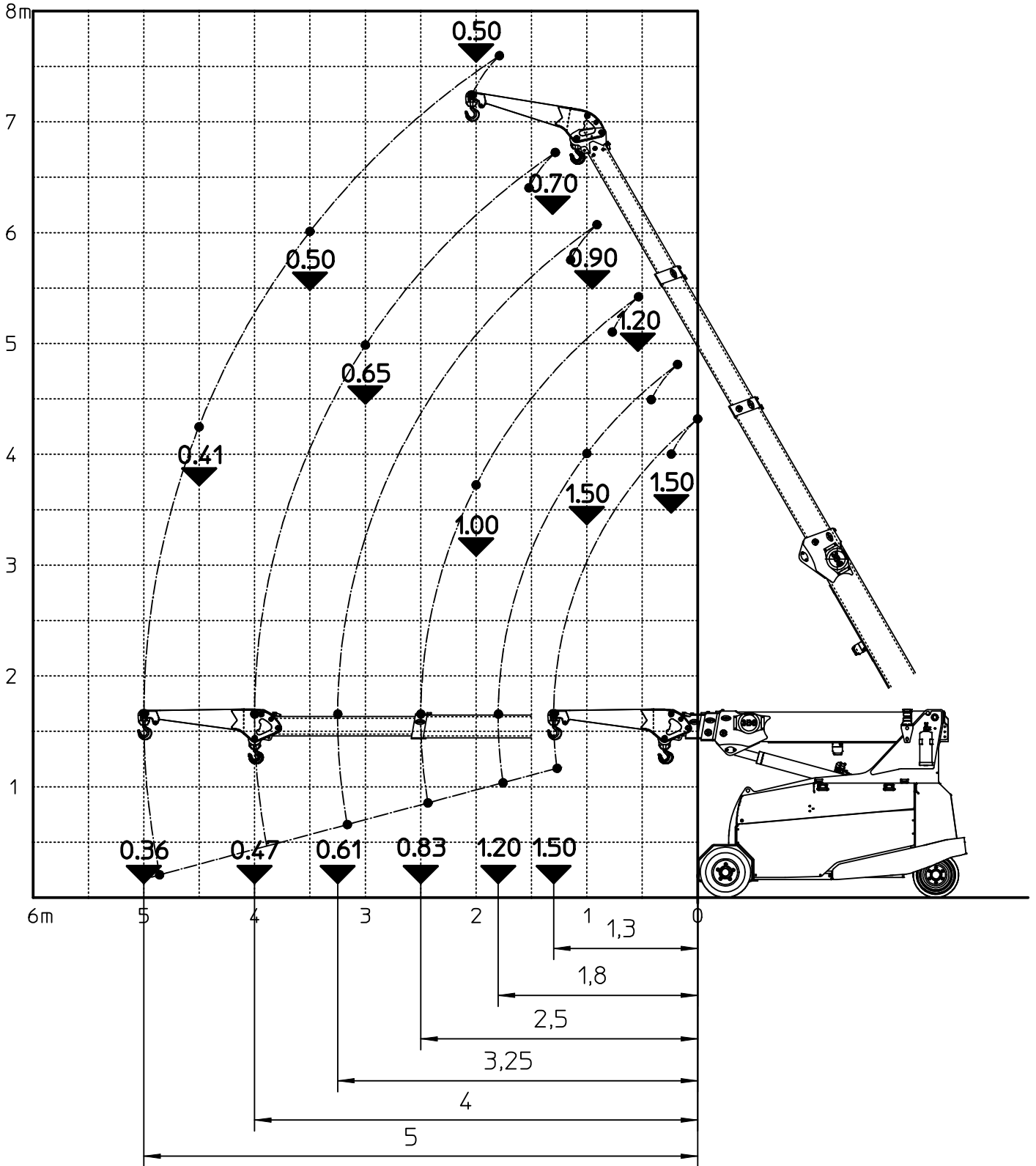

MC32

COD. 090-DIA-0068100 H1:50

DIAGRAMMA DELLE PORTATE (t)
 CAPACITY DIAGRAM (t)
 TRAGLASTDIAGRAMM (t)
 LASTENDIAGRAM (t)
 TABLEAU DES CHARGES (t)
 DIAGRAMA DE LAS CARGAS (t)

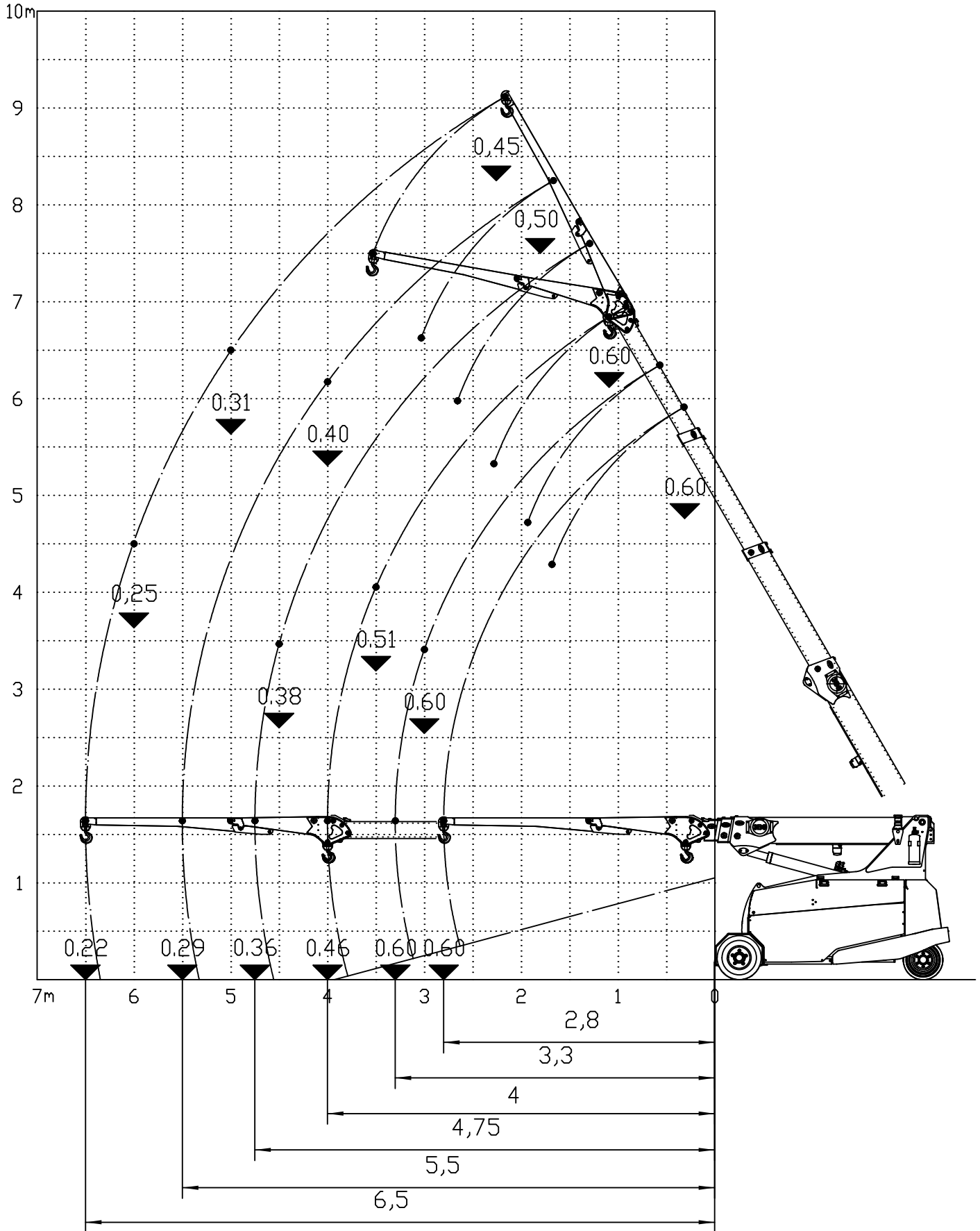

MC32